

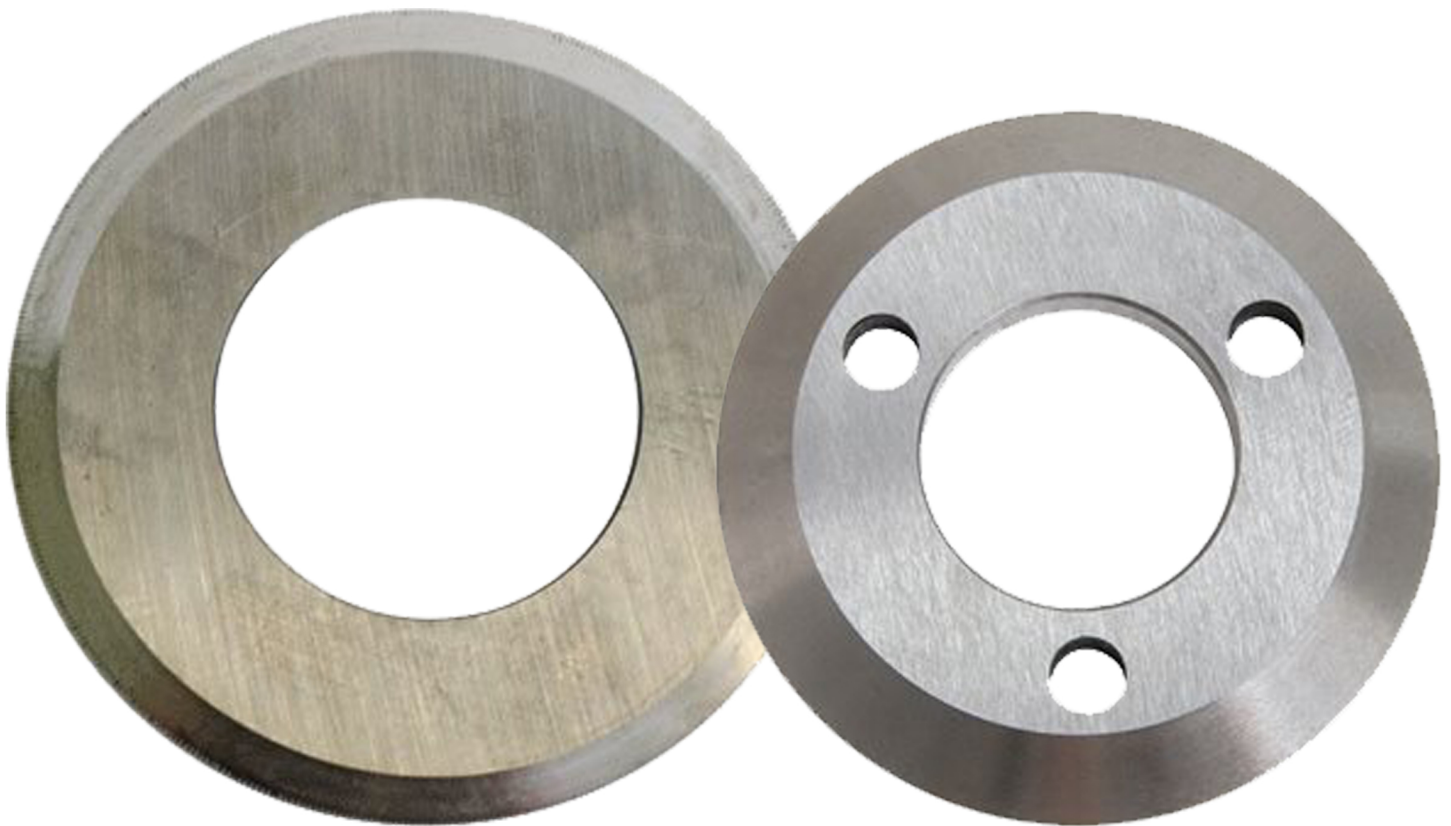

## **Rosback**

Perforators and Slitters



Please visit our website to explore our full list of products.  
[www.updateltd.com](http://www.updateltd.com) | 1-800-229-0009

## Quick tips on choosing correct blades:

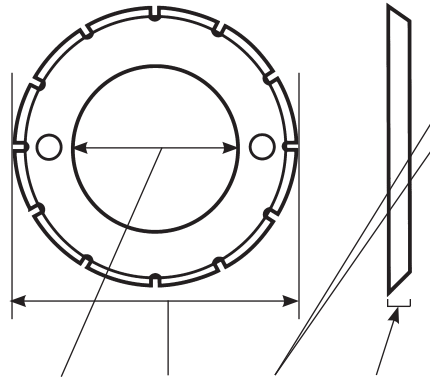

# Teeth = Total number of teeth on perf  
 # TPI = Number of teeth per inch  
 (These are generally referred as micro perfs.)

**NOTE!** Lots of problems are caused by dull perfs, slitters and die blocks.

ID	OD	#Teeth	Thick
26mm	39mm	12	0.5mm
Stahl#	200-750-06-00		
Update#	SP200		

**This guide is organized first by shaft size, smallest to largest...  
 Then by number of teeth, fewest to most (except micro perfs).**

**All images in this guide are actual size for comparison.**

### “V” shaped tooth



- Maximizes the distance between each tooth in perfs with a low number of teeth such as 6, 8, 12 or 18.
- Increases the strength of the teeth in perfs with a high number of teeth such as 60, 72, 80 or more.
- Lower # of teeth (12-18) better for backbone on perfect bound books - sigs won't tear.

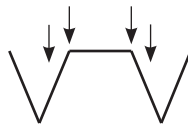

#### Also

If shaft is adjustable, a slightly wider perf cut can be made.

### Crimping perf

- Holds sheets together temporarily.
- Used for processing zig zag folded sheets on a gather - stitcher and envelopes on a perfect binder.

### Knockout (punch) perf

- Use when printed product needs perforation in the spine for adhesive binding or air relief.

### Reverse Tooth

Standard



Reverse



- Assumes blades are placed on upper slitter shaft.
- Holds fold together on 16 page books.

### Round Tooth

- Good for perfin multiple sheets at a time.



# ROSBACK\*

## PERFORATORS

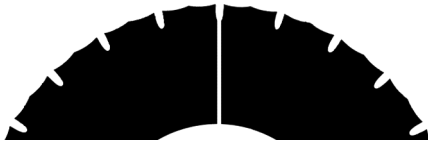

ID	OD	#Teeth	Thick
1.250mm	63.5mm	24	.5mm
Des.	Perf (dbl scallop)		
Update#	221-28-3		

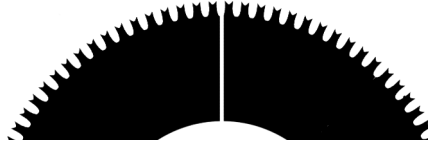

ID	OD	#Teeth	Thick
1.250mm	63.5mm	26	.5mm
Des.	Perf (scallop)		
Update#	221-28-12		



ID	OD	#Teeth	Thick
1.250mm	63.5mm	30	.5mm
Des.	Perf (dbl scallop)		
Update#	221-28-4		

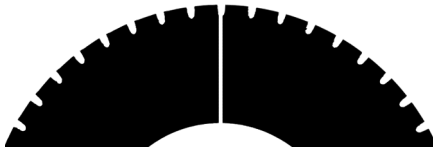

ID	OD	#Teeth	Thick
1.250mm	63.5mm	48	.5mm
Des.	Perf		
Update#	221-277-6		



ID	OD	#Teeth	Thick
1.250mm	63.5mm	48	.5mm
Des.	Perf (scallop)		
Update#	221-28-6		

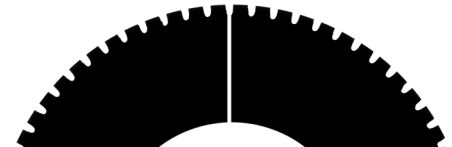

ID	OD	#Teeth	Thick
1.250mm	63.5mm	66	.5mm
Des.	Perf		
Update#	221-277-9		



ID	OD	#Teeth	Thick
1.250mm	63.5mm	66	.5mm
Des.	Perf (scallop)		
Update#	221-28-9		

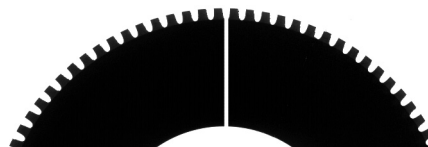

ID	OD	#Teeth	Thick
1.250mm	63.5mm	92	0.5mm
Des.	Perf		
Update#	221-277-12		

# BOWE TRIMMER\*

## SLITTERS

Not Pictured

Not Pictured

ID	OD	#Teeth	Thick
.788mm	1.834mm	-	.200mm
Des.	Top slitter, single edge, 3 hole		
Update#	BW7334		

ID	OD	#Teeth	Thick
.788mm	1.834mm	26	.200mm
Des.	Bottom slitter, sq. edge, 3 hole		
Update#	BW7354		

\*Rosback is a registered trademark of Rosback