

Always disconnect the power supply before making any adjustments or servicing the stitcher.

WARNING

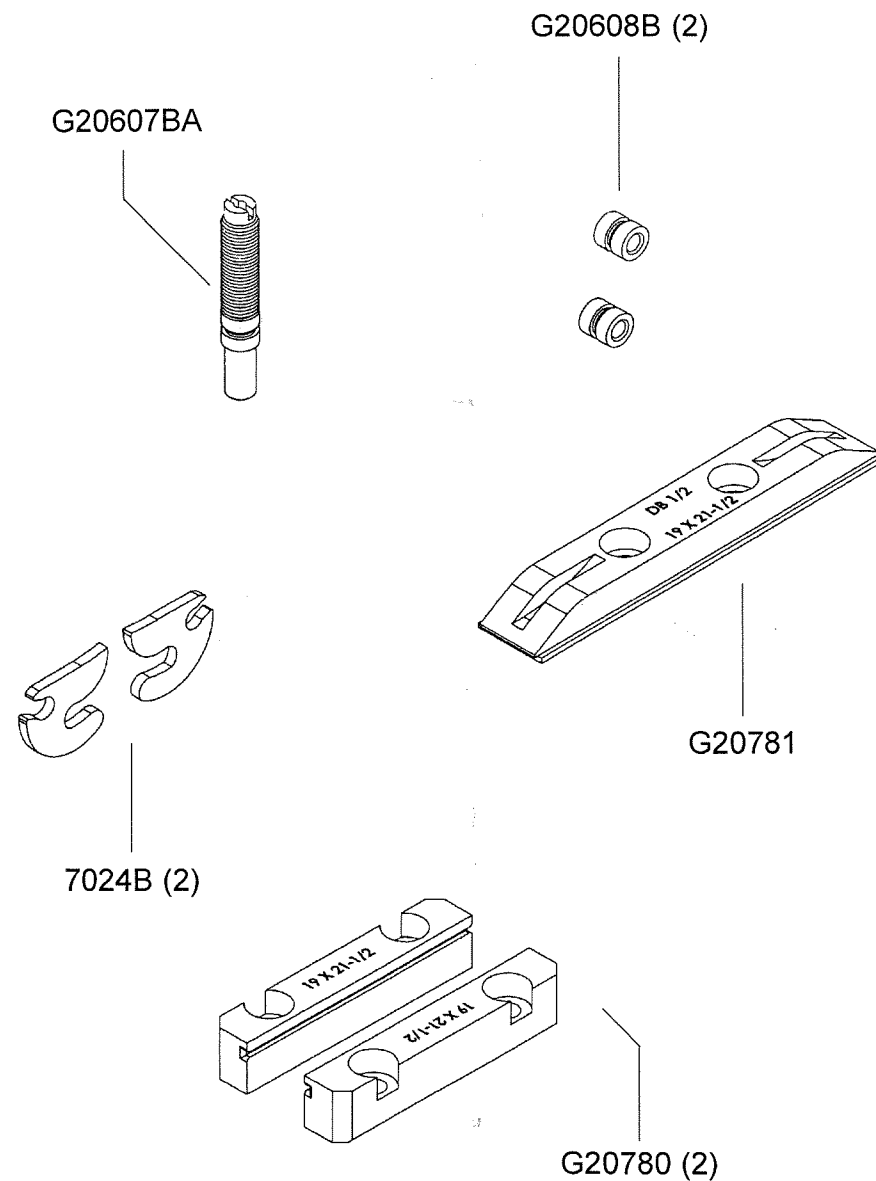

Figure 1 - Installation

The G20 19x21 Conversion Kit allows existing G20 Stitcher Heads to accommodate 19x21 gauge flat wire. 19x21 gauge flat wire allows your M19G20, M27G20 and other collating systems to consistently stitch at a higher capacity through thicker stock.

1. Remove the three (3) screws securing the Cutter Box Assembly (**G20597BA**) to the stitcher head and remove the whole Assembly.
2. Press the two (2) Wire Roller Studs (**G20612**) out of the Cutter Box Assembly from the back of the Assembly. Be careful not to damage the Cutter Box itself as it is soft. Slip the existing Wire Rollers (**G20608**) off of the studs.
3. Loosen and remove the Hex Nut (**G20624**) and Screw (**G20589**) securing the Straightener Arm (**G20613**) to the Wire Roller Assembly (**G20607A**). Remove the Wire Roller Assembly from the Cutter Box Assembly and completely remove the Straightener Arm from the Wire Roller Assembly.
4. Replace the Straightener Arm (**G20613**) on the Wire Roller Assembly (**G20607BA**) so that the machined hole lines up with the Cam on the Straightener Slide (**G20606A**). Secure this position with a Screw (**G20589**). Make sure the grooves in the two (2) Wire Rollers (**G20608**) and the Wire Roller Assembly (**G20607BA**) line up. Secure this position with the Hex Nut (**G20624**). For further instructions, refer to the G20 Operation and Maintenance Manual.
5. Press two (2) Wire Roller Studs (**G20612**) through two (2) Wire Rollers (**G20608B**) and into the Cutter Block Assembly (**G20597BA**). Check to make sure that the Rollers spin freely, if not either press the Studs out slightly from the back or add some S.A.E. #10 oil to the Rollers.
6. Loosen and remove the four (4) Screws (**G20589** or **G20618**) securing the Bender Inserts to the Bender Bar (**G20547**). Exchange the two (2) Bender Inserts (**G20780**) with the existing pair on the Bender Bar.
7. Exchange the two (2) Clincher Points (**7024B**) with the existing pair in the Clincher Plate.

ITEM No.	DESCRIPTION	QUANTITY
7024B	Clincher Point, Flat - 1/2	2
G20607BA	Wire Roller Assembly 1921	1
G20608B	Wire Roller 1921-1/2	2
G20780	Bender Insert 1921 Gauge	2
G20781	Driver 1/2 - 1921 Gauge	1